

Hinged Lid Compartments

Neoprene Seals at Base and Below Lid

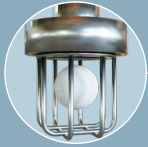

Oil Gravity Ball

Integral Vented Flow Control

Effluent Inflow

Strainer Basket

Silt Valve

Water Outflow

Immersion Heater

Main Separation Chamber

Oil Collection Cassette

## Goslyn GOS60

15 GPM Automatic Grease Removal Device

### Goslyn products outperform other systems on the market

Goslyn is a leading innovator in grease removal technology, specializing in sustainable, environmentally-friendly automatic grease removal devices and related solutions.

Our patented, high-efficiency, cost-effective systems offer a range of unique features and benefits that set Goslyn apart from similar products on the market.



## Efficiency and Effectiveness

In the foodservice industry, significant amounts of fats, oils, and greases (FOG) mix with water and are flushed down the drain. This FOG-polluted water is costly and detrimental, as it clogs drains, burdens sewage systems, and pollutes the environment.

So why not stop FOG at its source?

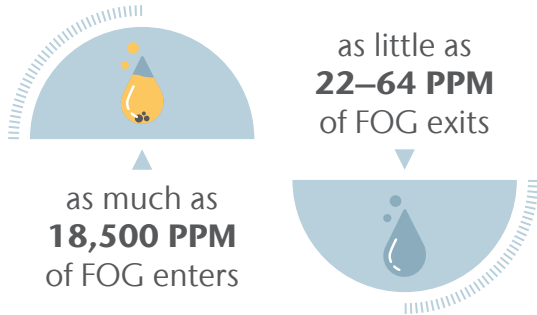

Along with FOG, Goslyn systems consistently achieve a 96.4% grease removal efficiency, outperforming competing systems in the market.

## Convenient Compact Build

The Goslyn GOS60 features a unique system design that allows for multiple discharge configurations while maintaining a small footprint, making it easy to install and retrofit.

## Durability and Low Maintenance

Customers across various industries leverage Goslyn solutions to ensure they have effective and reliable systems in place. Thanks to the durability and longevity of our products, customers also benefit from a positive return on investment.

- Heavy-duty 14 gauge, grade 304 stainless steel exterior construction
- No moving parts = less maintenance
- 5 year limited warranty

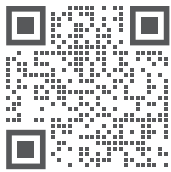

ACO, Inc.

825 W. Beechcraft St.  
Casa Grande, AZ 85122  
Tel: (520) 421-9988

goslyn@aco.com

© July 2024 ACO, Inc.  
All reasonable care has been taken in compiling the information in this document. All recommendations and suggestions on the use of ACO products are made without guarantee since the conditions of use are beyond the control of the company. It is the customer's responsibility to ensure that each product is fit for its intended purpose and that the actual conditions of use are suitable. ACO, Inc. reserves the right to change products and specifications without notice.

## GOS60 Details

Part No.	139560
Flow Rate	15 GPM
Height	14.27" (362 mm)
Length <sup>1</sup>	37.37" (949 mm)
Width <sup>2</sup>	16.00" (406 mm)
Height to Inlet Center <sup>3</sup>	10.04" (255 mm)
Height to Outlet Center <sup>3</sup>	7.80" (198 mm)
Weight	115.0 lbs

1. Length does not include Silt Valve.
2. Width does not include 3.5" for cassette and oil shroud.
3. Inlet/Outlet height is measured to the center.

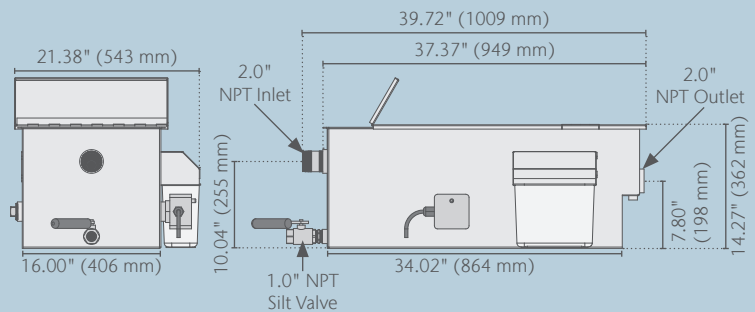

### Typical Applications



Goslyn GOS60 meets (and exceeds) industry codes and standards including UL, IPC, UPC, IRC, NPC, ASME A112.14.3, ASME A1123.14.4, and PDI G101.



ACO. we care for water

