

Goslyn - GOS160

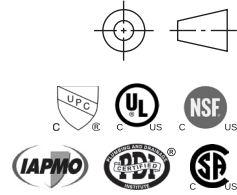
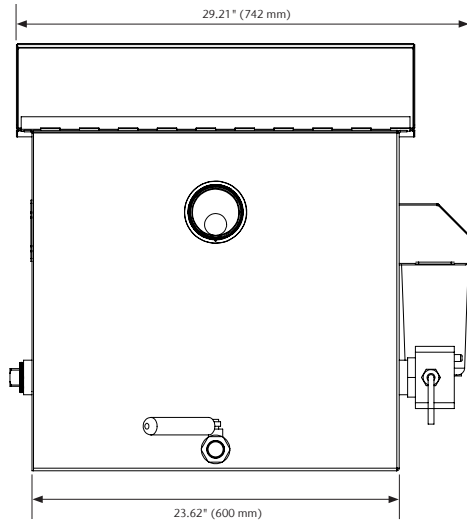

Specification Clause

Shall be a Goslyn Model: GOS160 grease removal device / immiscible liquid separator which continuously operates under hydro static pressure with no moving parts. Is made of 2 mm, 304 stainless steel and comes standard with an immersion heater. It has a capacity of 50 gallons per minute.

Electrical Requirements

- 110 Volt, 1000 Watts, 9 Amps within 5' of unit

Required Clearances

- Headroom needed above strainer basket: 12"
- 2" NPT inlet
- 2" NPT outlet
- Access to front Oil Cassette
- Access to hinged lid for Oil Valve

The Goslyn Outlet may discharge either indirectly (e.g., into a floor sink) or directly to a drain pipe.

ACO recommends checking local plumbing codes prior to installation.

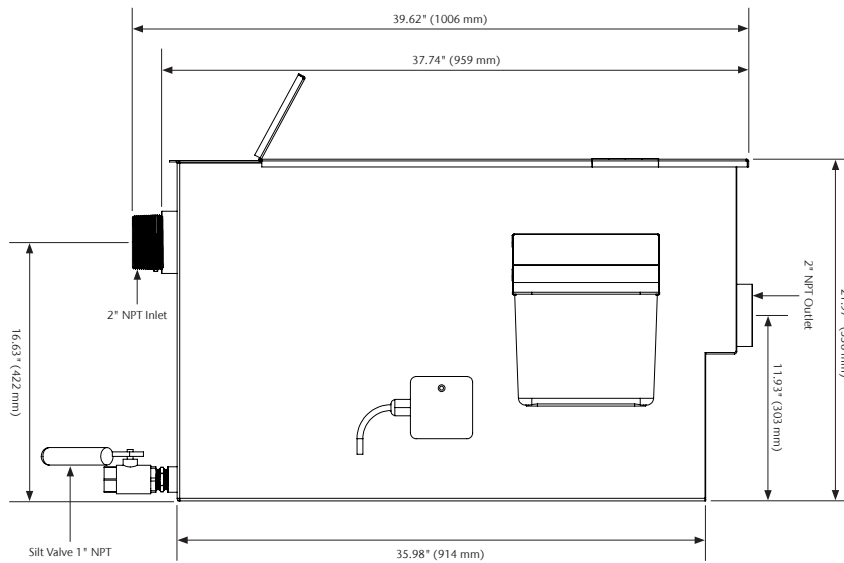

Strainer Basket

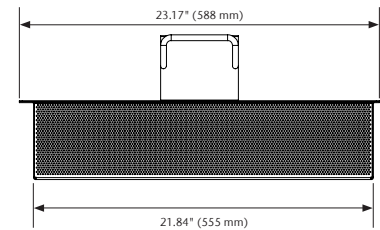
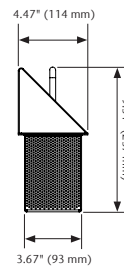

	Part No.	ACRD Separator	Weight lbs
GOS160	139516	50 GPM	220.0

ACO, Inc.

West Sales Office
 825 W. Beechcraft Street
 Casa Grande, AZ 85122
 Tel: (520) 421-9988
 Toll-Free: (888) 490-9552
 Fax: (520) 421-9899

goslyn@aco.com
 www.acousa.com
 www.goslyn.com



© March 2023 ACO, Inc.
 All reasonable care has been taken in compiling the information in this document. All recommendations and suggestions on the use of ACO products are made without guarantee since the conditions of use are beyond the control of the company. It is the customer's responsibility to ensure that each product is fit for its intended purpose and that the actual conditions of use are suitable. ACO, Inc. reserves the right to change products and specifications without notice.

